

THACO AUTO



COACH



EXTERIOR



GRILLE
Featuring a completely new design with the Thaco Bus logo and the chrome horizontal bars, harmoniously blend modernity and sophistication



HEADLAMP
Integrated Halogen Projector headlights and LED daytime lights, turning signal LED lights, modern and aesthetic



REARVIEW MIRROR
Designed to be anti-vibration, with integrated power-adjustment and modern mirror heating feature to ensure safety when reversing



SMART KEY
Remote door opening/closing and finding the parked car

DESIGN LANGUAGE
SENSORY CONTRIVE

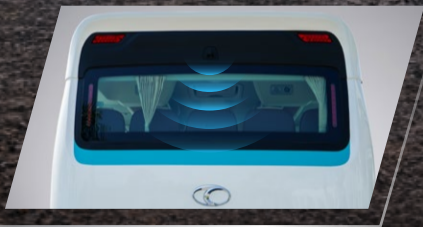

INFRARED CAMERA

Designed to be hidden in the rear spoiler, providing a good viewing even at night



REAR LAMP CLUSTER

Integrated brake lights, turn signals, and reverse light



DUAL EXHAUST PIPES

Balanced and harmonious designed with stainless steel covers



ALUMINUM ALLOY WHEEL

From Alcoa (USA)



INTERIOR

SPACIOUS AND LUXURIOUS



The LED lighting system is modern and luxurious



Equipped with engine start-stop button



The cockpit is elegantly designed with a spacious and luxurious interior

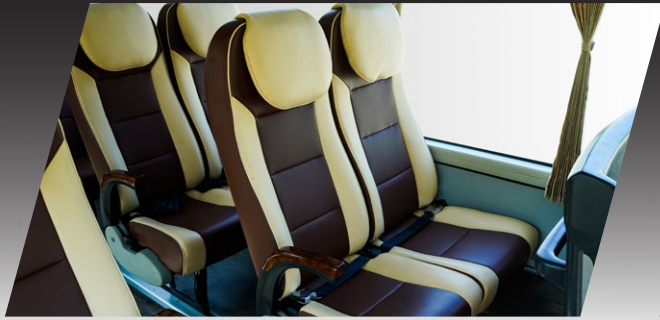

Passenger seats are designed suitable for body anthropometry

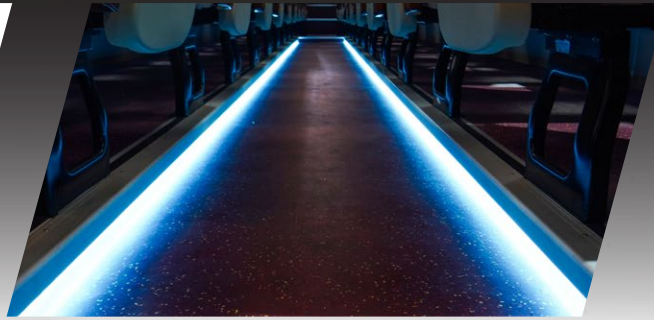

Aisle for convenient movement



Spacious luggage compartment

NEW **BlueSKY**



12.180 mm



Layout of 47 seats

Ever **GREEN 875**



8.730 mm



Layout of 29 seats



Layout of 34 seats

Ever **GREEN 815**



8.180 mm



Layout of 29 seats

CHASSIS

MONOCOQUE GEN II

The monocoque chassis meets European standard ECE R66 for frame durability. This design enhances structural rigidity and optimizes vehicle weight and fuel efficiency. The chassis is ED coated using state-of-the-art technology, ensuring its durability and life span. The NEWAY suspension system and 06 DOMBETTER airbags from the Netherlands, along with a stabilizer bar for its smooth operation in different types of terrains.

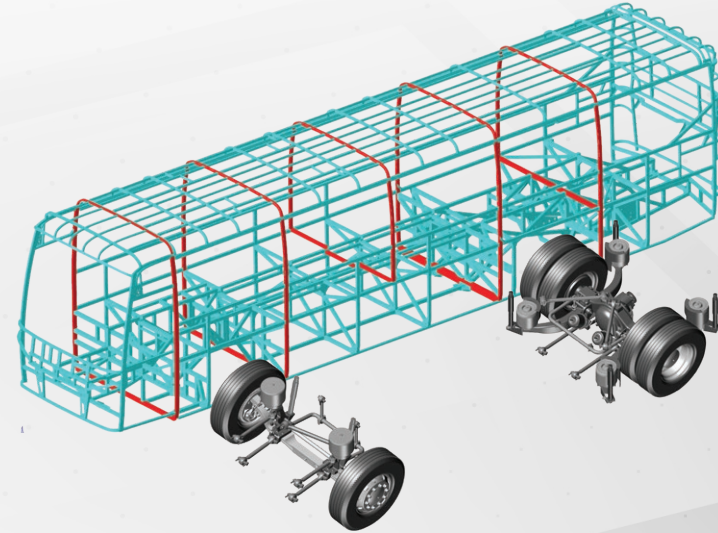

ENGINE

The **Weichai engine - WP9H336**, featuring an electronically controlled Common Rail System (CRDi) fuel injection system, enhances the vehicle's powerful performance and fuel-saving.

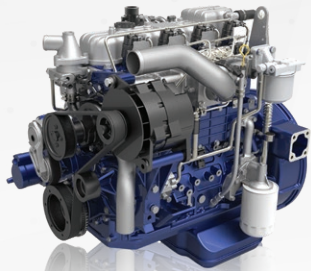

EverGREEN 815

MAX. POWER:
170 Ps / 2600 Rpm

MAX. TORQUE:
600 Nm / 1300 - 1900 Rpm



EverGREEN 875

MAX. POWER:
220 Ps / 2300 Rpm

MAX. TORQUE:
800 Nm / 1200 - 1800 Rpm



NEW BlueSKY

MAX. POWER:
336 Ps / 1900 Rpm

MAX. TORQUE:
1660 Nm / 1000 - 1400 Rpm

SPECIFICATION

MODELS		EVERGREEN 81S	EVERGREEN 87S	NEW BLUESKY
DIMENSION				
Overall dimension (LxWxH)	mm	8.180 x 2.300 x 3.100	8.730 x 2.300 x 3.100	12.180 x 2.500 x 3.480
Front tread	mm	1.885	1.860	2.092
Rear tread	mm	1.705	2.610	1.902
Wheelbase	mm	3.900	4.260	6.000
Min. Ground Clearance	mm	165	150	150
WEIGHT				
Curb weight	kg	7.470	7.845	12.535
Max. Weight	kg	9.575	9.960	16.000
Seat capacity	Seater	29	29/34	47
CHASSIS				
		THACO	THACO	THACO
ENGINE				
Brand		Weichai - WP4.1N170E4	Weichai - WP4.6N220E40	Weichai - WP9H336E40
Type		Diesel, 4-stroke, 4-cylinder in-line, turbocharger, water-cooler	Diesel, 4-stroke, 4-cylinder in-line, turbocharger, water-cooler	Diesel, 4-stroke, 6-cylinder in-line, turbocharger, water-cooler
Displacement	cc	4.088	4.580	8.800
Bore x stroke	mm	105 x 118	108 x 125	116 x 139
Max. Power/rpm	Ps	170/2.600	220/ 2.300	336/ 1.900
Max. torque/rpm	Nm	600/1.300 – 1.900	800/ 1.200 - 1.800	1.660 / 1.000 ~ 1.400
TRANSMISSION				
Clutch		1 disc dry friction, hydraulic drive	1 disc dry friction, hydraulic drive	1 disc dry friction, hydraulic drive, vacuum booster
Gearbox		Mechanic, Manual Transmission, 06 forward and 01 reverse		Mechanic, Manual Transmission, 06 forward and 01 reverse, pneumatic-assisted
Ratio		ih1 = 6,67; ih2 = 4,01; ih3 = 2,42; ih4 = 1,52; ih5 = 1,00; ih6 = 0,78; iR = 6,13	ih1 = 6,40; ih2 = 3,71; ih3 = 2,22; ih4 = 1,37; ih5 = 1,00; ih6 = 0,73; iR = 5,84	ih1 = 7,04; ih2 = 4, 10; ih3 = 2,48; ih4 = 1,56; ih5 = 1,00; ih6 = 0,74; iR = 6,26
STEERING SYSTEM				
		Recirculating ball with hydraulic assist		
BRAKING SYSTEM				
Type		Dual air brake		
Main Brake		Front: Disk brake; Rear: Drum brake, accumulator spring, impact on rear wheels	Drum type, pneumatic, accumulator spring, impact on rear wheels	
Auxiliary Brake		ABS, engine brake	ABS, Retarder	
SUSPENSION				
Front		2 air suspension and 2 shock absorber, stabilizers bar		2 air suspension and 2 shock absorber, stabilizers bar
Rear		4 air suspension and 2 hydraulic absorber, stabilizers bar		4 air suspension and 4 hydraulic absorber, stabilizers bar
TIRE				
		245/70R19.5 / Dual 245/70R19.5	245/70R19.5 / Dual 245/70R19.5	295/80R22.5/ Dual 295/80R22.5
DYNAMICS PERFORMANCE				
Gradeability	%	37,3	46,7	46,9
Min. Turning radius	m	7,7	8,3	10,6
Max. Speed	km/h	104	109	125
Fuel Tank Capacity	Liter	100	140	340

THACO AUTO

THACO AUTO CO., LTD

 Tam Hiep Commune, Nui Thanh District, Quang Nam Province, Vietnam

 www.thacoauto.vn